



# ***PRESSURE SEAL VALVES***



**YOUR SUCCESS IS OUR COMMITMENT**

**PT Mossa Karya Utama**

## STANDARD FEATURES

### DESIGN

SUNE pressure seal valves are intended for high pressure, high temperature application in all types of fluid except where severe coking is a factor.

The design and material selections provide excellent service in nuclear steam generating stations, industrial and chemical plants and thermal power plants. Our pressure seal valves provide the most efficient flow passage and sealing features possible resulting in significant weight savings, ease of installation and maintenance features.

Manufacturing and quality assurance procedures include extra controls on dimensional, nondestructive examination and testing of critical areas such as the gasket sealing, butt-weld ends, and stellite sealing surfaces.

### Construction

#### 1. Body and Bonnet

**BODY:** Flow areas are designed for minimum turbulence and pressure drop.

**BONNET:** Ample stuffing box and stellite stem guide and back seat shoulder are provided for accurate guiding of the stem and back seat. Cast body and bonnet quality requirements are considered in design of SUNE valves.

#### Bonnet Type

##### Type A

##### GATE

Class 600, 900, 1500 & 2500  
Size 4" & smaller

##### GLOBE

Class 600, 900, 1500  
Size 4" & smaller  
Class 2500  
Size 3" & smaller

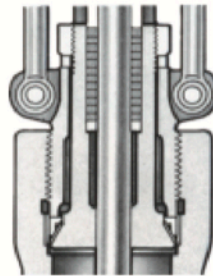

##### Type B

##### GATE

Class 600, 900, 1500 & 2500  
Size 6" & larger

##### GLOBE

Class 600, 900, 1500  
Size 6" & larger  
Class 2500  
Size 4" & larger

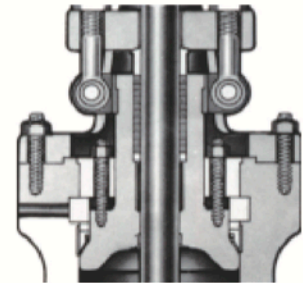

##### Type C

##### SWING CHECK

Class 600, 900 & 1500  
Size 4" & smaller  
Class 2500  
Size 3" & smaller

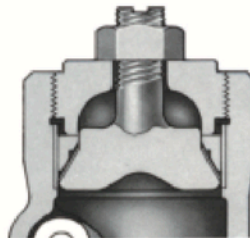

##### Type D

##### SWING CHECK

Class 600, 900 & 1500  
Size 6" & larger  
Class 2500  
Size 4" & larger

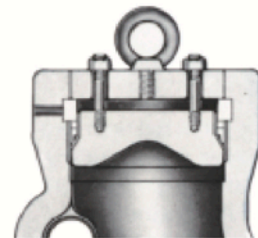

#### 2. Wedge (Gate Valve)

The flexible wedge is a one piece, fully guided cast wedge with a central hub to allow the seating faces to move relative to each other thus compensating for distortion of the body seats due to thermal expansion or piping loads. Seat ring and wedge seating surface are set at a nine degree angle from vertical to minimize sliding contact of the wedge and seat ring during opening and closing.

Wedging actions help effect a tight seal in low differential pressure services. Flexible wedge construction resists wedge sticking or binding in services where the valve may be closed when hot and opened when cold. Seating surfaces are stellite to provide high cycle capability.

## STANDARD FEATURES

### 3. Disc (Globe & Swing Check Valve)

Globe and check type discs are accurately fitted and guided to minimize vibration. Seating surfaces are stellite.

### 4. Hammer Blow Type Hand Wheel & Ball Bearing Type Yoke Sleeve

All globe valves are equipped with hammer blow type hand wheel. Two integrally cast lugs on the upside of hand wheel simultaneously strike a steel crossbar which is connected directly to valve stem on smaller sizes or to the yoke sleeve on large sizes.

#### Bearing Blow Type Yoke Sleeve

Large, high pressure valves can require a tremendous valve. Use of ball bearings in the yoke sleeve to operate valves by as much as 50 percent.

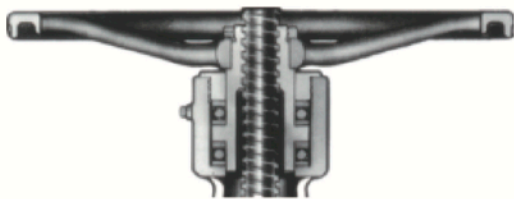

CLASS	GATE	GLOBE
600	Size 6" & Larger	Size 6" & Larger
900	Size 2", 2-1/2", 6" & Larger	
1500	Size 2" & Larger	Size 3" & Larger
2500		

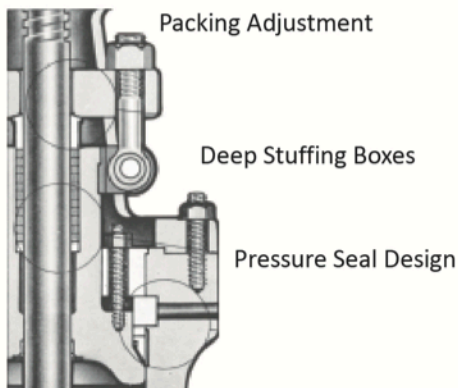

### 5. Standard Pressure Seal Design

The segmental thrust ring absorbs all the thrust applied by internal pressure.

A hardened stainless steel protective ring prevents deformation of the top surface of the soft metallic gasket. The gasket can be removed freely without the sealing surface of the body damaging.

### 6. Packing Adjustment

All gate and globe valves are provided with a two piece packing gland to minimize the possibility of scoring the stem if the gland is tightened unevenly. Eye bolt remains fastened to the bonnet.

They swing out of the way to simplify packing replacement and are oriented so they can be adjusted from one side of the valve.

### 7. Deep Stuffing Boxes

Deep stuffing boxes are standard on gate and globe valves. The design provides extra packing for a more reliable stem seal, or sufficient depth for packing with an optional lantern ring in the middle. When equipped with a lantern ring, a tapped and plugged hole is provided. When specified, it can be fitted with a ball grease injector.

## ***MOTOR OPERATED & BEVEL GEAR OPERATED VALVES***

### **Motor Operated Valves**

All SUNE valves can be equipped with electric, pneumatic motor operators.

Customers are asked, when ordering, to specify the following requirements that may enable us to supply the correct size of operator.

1. Medium
2. Working temperature
3. Working pressure
4. Differential pressure across the valve
5. Nominal diameter of the valve
6. Type of actuator
7. Voltage and frequency, or air pressure
8. Closing time
9. The need for position indicators or position transmitter etc.
10. Number and type of any auxiliary contact required.
11. Special classes of insulation
12. Waterproof or explosion proof

### **Bevel Gear Operated Valves**

SUNE bevel gear, valve operators are directly mounted to the gate and globe valves

which receive the thrust loads. This results in easy manual opening and closing of the valves. The unit is of compact design with integral thrust bearings.

### **Characteristics**

1. The unit is of fully enclosed construction, filled with high pressure grease and ready for immediate use.
2. The unit results in easy valve operation and has a hammer blow device.
3. The stem nut is driven by involute splines. The stem nut may be easily removed from the unit for machining the threads.
4. The stem cover and stem plug are all optional equipment.

## GATE VALVES STANDARD FEATURES

### Service Recommendation

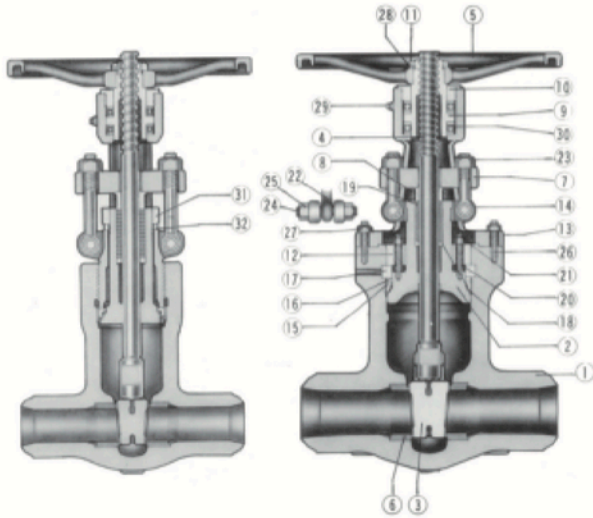

1. Gate valves are normally used for on-off service. They are not recommended for throttling service.

2. Gate valves are normally installed in horizontal pipe runs with the valve stem vertically up. They can also be installed in vertical or horizontal pipe runs with the valve stem other than vertical, but special construction may be required depending on valve size, service, conditions, and material. When purchasing valves for other than the normal installation, valve orientation should be specified.

3. After closing a gate valve with sufficient force to develop shutoff, the stem should be backed off slightly (1/8 to 1/4 turn) to relieve stem load. This will enable the stem to expand slightly without bending or damaging the valve and will not affect valve shutoff.

### Pressure Rating

Class 600      Class 900      Class 1500      Class 2500

### Pressure Rating

No.	PART NAME	A216 WCB	A217 WC6	A217 WC9	A217 C5	A351 CF8M
1	Body	A216 WCB	A217 WC6	A217 WC9	A217 C5	A351 CF8M
2	Bonnet	A216 WCB	A217 WC6	A217 WC9	A217 C5	A351 CF8M
3	Wedge	A216 WCB + Stellite	A216 WCB + Stellite	A217 WC9 + Stellite	A217 C5 + Stellite	A351 CF8M + Stellite
4	Stem	A182 F6	A182 F6	A182 F6	A182 F6	A182 F316
5	Hand Wheel	A197 or WCB	A197 or WCB	A197 or WCB	A197 or WCB	A197 or WCB
6	Body Seat Ring	A105 + Stellite	A182 F11 + Stellite	A182 F22 + Stellite	A182 F5a + Stellite	A182 F316 + Stellite
7	Gland Flange	A283-D	A283-D	A283-D	A283-D	A283-D
8	Packing Gland	C/S 1020 + Cr Plate	C/S 1020 + Cr Plate	C/S 1020 + Cr Plate	C/S 1020 + Cr Plate	A479-316
9	Yoke Sleeve	A439-D2C	A439-D2C	A439-D2C	A439-D2C	A439-D2C
10	Yoke Cap	C/S1020	C/S1020	C/S1020	C/S1020	C/S1020 + Cr Plate
11	Hand Wheel Nut	C/S1020	C/S1020	C/S1020	C/S1020	C/S1020 + Cr Plate
12	Bonnet Clamp	C/S 1045	C/S1045	C/S1045	C/S1045	A351 CF8M
13	Yoke	A216 WCB	A217 WC6	A217 WC9	A217 C5	A351 CF8M
14	Hinge Clamp	A216 WCB	A217 WC6	A217 WC9	A217 C5	A351 CF8M
15	Gasket	Soft Steel	Soft Steel	Soft Steel	Soft Steel	316S S
16	Adapter Ring	A479-410	A479-410	A479-410	A479-410	A479-316
17	Retainer	A479-410	A479-410	A479-410	A479-410	A479-316
18	Stuffing Ring	A479-410	A479-410	A479-410	A479-410	A479-316
19	Packing	Graphite	Graphite	Graphite	Graphite	Graphite
20	Bonnet Bolt	A193-B7	A193-B16	A193-B16	A193-B16	A193-B8
21	Nut	A194-2H	A194Gr4	A194Gr4	A194Gr4	A194Gr8
22	Gland Bolt	A307 B	A193-B7	A193-B7	A193-B7	A193-B8
23	Nut	A307 B	A194-2H	A194-2H	A194-2H	A194-9
24	Gland Clamp Bolt	A307 B	A193-B7	A193-B7	A193-B7	A193-B8
25	Nut	A307 B	A194-2H	A194-2H	A194-2H	A194-9
26	Yoke Bolt	A193-B7	A193-B7	A193-B7	A193-B7	A193-B8
27	Nut	A194-2H	A194-2H	A194-2H	A194-2H	A194-8
28	Set Screw	C/S1020	C/S1020	C/S1020	C/S1020	C/S1020
29	Grease Nipple	Steel	Steel	Steel	Steel	Steel
30	Bearing	Steel	Steel	Steel	Steel	Steel
31	Bonnet Clamp	C/S1045	C/S1045	C/S1045	C/S1045	A351CF8M
32	Washer	A479-410	A479-410	A479-410	A479-410	A479-304

## PRESSURE SEAL GATE VALVES

1. Swing eyebolts and gland flange facilitate repacking.
  2. Inner row of studs establish the initial seal of the Pressure Seal Joint.
  3. By inserting knockout pin in drilled hole, segmental thrust ring can be easily driven out of retaining groove.
  4. Segmental thrust ring absorbs all the thrust applied by internal pressure.
  5. Stellite back seat area provides accurate guiding of stem.
  6. Streamline contour of body simplifies application and reduces cost of insulation, and effects marked savings in space and weight.
  7. Seat rings are stellite faced and securely welded in place.
  8. Accurately machined Acme threads prolong the life of the stem and bushing.
  9. Bearings for ease of operation.
  10. Outer row of studs secures the yoke-arm to the body.
  11. A hardened stainless steel protective ring prevents deformation of the top portion of the soft metallic gasket.
  12. The bonnet joint remains tight under all operating conditions as the sealing pressure is always many times greater than the pressure of the fluid in the line, thereby eliminating leakage. The higher the internal pressure, the greater the sealing pressure. The gasket can be removed freely without damage to the sealing area in the body.
  13. Stellite faced flexible "H" type wedge prevents sticking due to temperature changes and pipe line stresses.
- One piece flexible wedge with weld deposited stellite facings insures pressure tightness, prevents wedge from sticking and reduces operating torque needed to open valve. It also offers less resistance to unseating due to temperature changes.

### Design Data Feature

1. Complies with requirement of applicable standard: ASME B 16.25, 16.34, MSS-SP-25, Optional API 600.
2. OS & Y construction, rising stem, non-rising handwheel.
3. Sealing surface of body seat ring and wedge in all sizes are hard face with stellite.
4. Flexible wedge with TEE-HEAD STEM-TO-WEDGE connection.
5. Buttwelding end details of SUNE std. will be prepared in accordance with ASME B 16.25.

### Accessories

Accessories such as gear operators, actuators, bypasses, locking devices, and chainwheels are available to meet the customers requirements.

### Class 600

Dimensions in inches

Valve Size	2" 50mm	3" 80mm	4" 100mm	6" 150mm	8" 200mm	10" 250mm	12" 250mm	14" 350mm	16" 400mm	18" 450mm	20" 500mm	24" 600mm
Face to Face (L)	7.00	10.00	12.00	18.00	23.00	28.00	32.00	35.00	39.00	43.00	47.00	55.00
Handwheel Diameter (D)	7.87	12.40	13.98	17.72	19.69	24.80	27.95	31.50	35.43	35.43	43.00	43.00
Height (H)	19.96	22.95	28.00	35.67	45.71	53.07	60.16	66.34	78.98	86.30	97.63	112.95

### Class 900

Dimensions in inches

Valve Size	2" 50mm	3" 80mm	4" 100mm	6" 150mm	8" 200mm	10" 250mm	12" 250mm	14" 350mm	16" 400mm	18" 450mm	20" 500mm	24" 600mm
Face to Face (L)	8.50	12.00	14.00	20.00	26.00	31.00	36.00	39.00	43.00	48.00	52.00	61.00
Handwheel Diameter (D)	12.50	13.98	13.98	19.69	24.80	27.95	31.50	35.43	35.43	43.00	43.00	51.02
Height (H)	23.07	24.72	29.13	37.24	46.65	57.28	65.16	69.88	84.05	91.26	101.46	110.70

### Class 1500

Dimensions in inches

Valve Size	2" 50mm	3" 80mm	4" 100mm	6" 150mm	8" 200mm	10" 250mm	12" 250mm	14" 350mm	16" 400mm	18" 450mm	20" 500mm	24" 600mm
Face to Face (L)	8.50	12.00	16.00	22.00	28.00	34.00	39.00	42.00	47.00	53.00	58.00	76.50
Handwheel Diameter (D)	15.50	15.50	15.75	24.80	27.95	27.95	31.50	35.43	43.00	43.00	51.02	57.50
Height (H)	23.07	28.03	33.70	41.77	44.82	55.00	59.76	64.57	82.24	88.46	103.30	117.60

### Class 2500

Dimensions in inches

Valve Size	2" 50mm	3" 80mm	4" 100mm	6" 150mm	8" 200mm	10" 250mm	12" 250mm
Face to Face (L)	11.00	14.50	18.00	24.00	30.00	36.00	41.00
Handwheel Diameter (D)	15.50	15.50	15.75	24.80	27.95	27.95	31.50
Height (H)	25.63	31.14	37.44	46.41	49.80	61.11	66.40

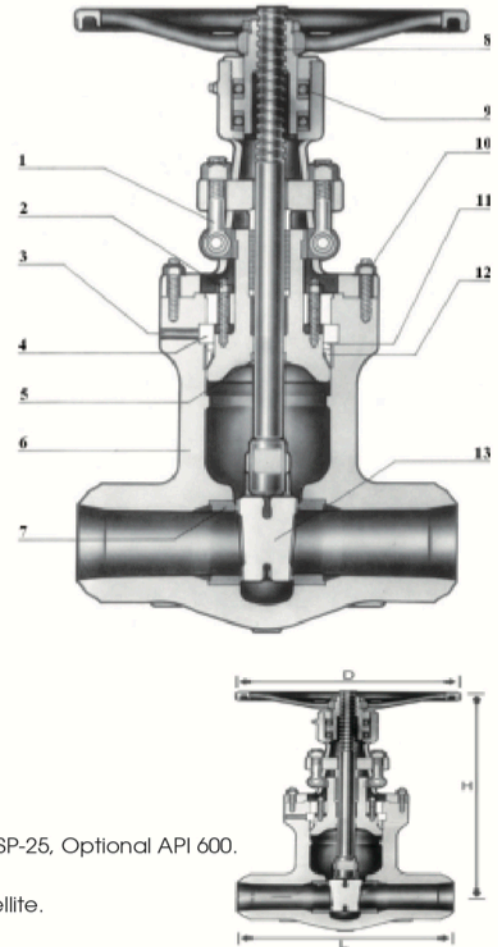

## GLOBE VALVES STANDARD FEATURES

### Service Recommendation

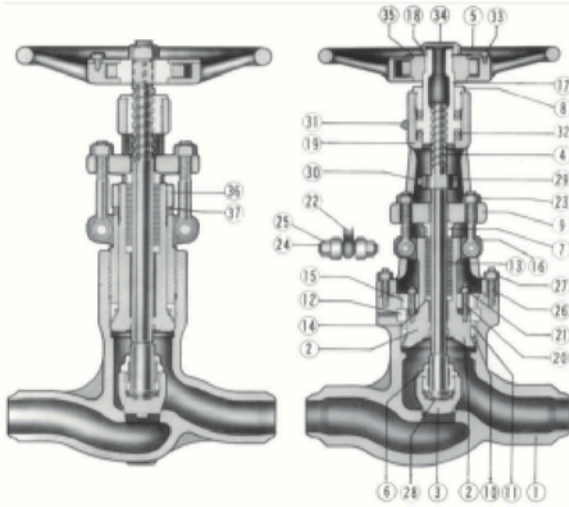

1. Globe valves are normally installed with flow and pressure under the disc.

Always check with the factory before installing valves with flow in the other direction. Under certain service conditions or when valves are equipped with cylinders or electric motor actuators, there may be a cost advantage in designing and installing the valves with flow over the disc. If actuators are sized for these conditions, care must be taken to assure valves are installed correctly.

2. Globe valves are suitable for most throttling applications; however, they should not be used for prolonged throttling at less than 10% open.

This can cause excessive vibration, noise and damage to disc and seats.

Use of smaller valves with lower flow capacity may avoid damage.

Continuous severe throttling applications may require a control valve.

### Pressure Rating

Class 600      Class 900      Class 1500      Class 2500

### Standard Parts and Materials

No.	PART NAME	A216 WCB	A217 WC6	A217 WC9	A217 C5	A351 CF8M
1	Body	A216 WCB	A217 WC6	A217 WC9	A217 C5	A351 CF8M
2	Bonnet	A216 WCB	A217 WC6	A217 WC9	A217 C5	A351 CF8M
3	Disc	A216 WCB + Stellite	A217 WC6 + Stellite	A217 WC9 + Stellite	A217 C5 + Stellite	A351 CF8M + Stellite
4	Stem	A479-410	A479-410	A479-410	A479-410	A479-316
5	Hand Wheel	A216 WCB	A216 WCB	A216 WCB	A216 WCB	A216 WCB
6	Lock Nut	A479-410	A479-410	A479-410	A479-410	A479-316
7	Packing Gland	C/S 1020 + Cr Plate	C/S 1020 + Cr Plate	C/S 1020 + Cr Plate	C/S 1020 + Cr Plate	A479-316
8	Yoke Cap	C/S1020	C/S1020	C/S1020	C/S1020	C/S1020 + Cr Plate
9	Gland Flange	A283-D	A283-D	A283-D	A283-D	A351-CF8
10	Gasket	Soft Steel	Soft Steel	Soft Steel	Soft Steel	316S S
11	Adapter Ring	A479-410	A479-410	A479-410	A479-410	A479-316
12	Retainer	A479-410	A479-410	A479-410	A479-410	A479-316
13	Packing	Graphite	Graphite	Graphite	Graphite	Graphite
14	Stuffing Box Ring	A479-410	A479-410	A479-410	A479-410	A479-410
15	Bonnet Clamp	C/S1045	C/S1045	C/S1045	C/S1045	A351CF8M
16	Hinge Clamp	A216 WCB	A217 WC6	A217 WC9	A217 C5	A351 CF8M
17	Yoke Sleeve	A439-D2C	A439-D2C	A439-D2C	A439-D2C	A439-D2C
18	Hand Wheel Nut	C/S1020	C/S1020	C/S1020	C/S1020	C/S1020 + Cr Plate
19	Yoke	A216 WCB	A217 WC6	A217 WC9	A217 C5	A351 CF8M
20	Bonnet Bolt	A193-B7	A193-B16	A193-B16	A193-B16	A193-B8
21	Nut	A194-2H	A194Gr4	A194Gr4	A194Gr4	A194Gr8
22	Gland Bolt	A307 B	A193-B7	A193-B7	A193-B7	A193-B8
23	Nut	A307 B	A194-2H	A194-2H	A194-2H	A194-8
24	Gland Clamp Bolt	A307 B	A193-B7	A193-B7	A193-B7	A193-B8
25	Nut	A307 B	A194-2H	A194-2H	A194-2H	A194-8
26	Yoke Bolt	A193-B7	A193-B7	A193-B7	A193-B7	A193-B8
27	Nut	A194-2H	A194-2H	A194-2H	A194-2H	A194-8
28	Disc Thrust Pad	A479-410	A479-410	A479-410	A479-410	A479-316
29	Stopper	A216 WCB	A217 WC6	A217 WC9	A217 C5	A351 CF8
30	Stopper Bolt	A307 B	A307 B	A307 B	A307 B	A193-B8
31	Nipple	Steel	Steel	Steel	Steel	Steel
32	Bearing	Steel	Steel	Steel	Steel	Steel
33	Bolt	A307 B	A307 B	A307 B	A307 B	A307 B
34	Set Screw	C/S1020	C/S1020	C/S1020	C/S1020	C/S1020
35	Name Plate	S S Plate	S S Plate	S S Plate	S S Plate	S S Plate
36	Bonnet Clamp	C/S1045	C/S1045	C/S1045	C/S1045	A479-304
37	Washer	A479-410	A479-410	A479-410	A479-410	A479-304

# PRESSURE SEAL GLOBE VALVES

1. Accurately machined Acme threads prolong the life of the stem and bushing.
2. Inner row of studs establish the initial seal of the Pressure Seal Joint.
3. Outer row of studs secures the yoke-arm to the body.
4. By inserting knockout pin in drilled hole, segmental thrust ring can be easily driven out of retaining groove.
5. Streamline contour of body simplifies application and reduces cost of insulation, and effects marked savings in space and weight.
6. Stellited back seat seal area provides accurate guiding of stem.
7. All globe valves are equipped with hammer blow type hand wheels. Two integrally cast lugs on the upside of the hand wheel simultaneously strike a steel crossbar.
8. Bearings for ease of operation.
9. Swing eyebolts and gland flange facilitate repacking.
10. Segmental thrust ring absorbs all the thrust applied by internal pressure.
11. A hardened stainless steel protective ring prevents deformation of the top portion of the soft metallic gasket.
12. The bonnet joint remains tight under all operating conditions as the sealing pressure is always many times greater than the pressure of the fluid in the line, thereby eliminating leakage. The higher the internal pressure, the greater the sealing pressure. The gasket can be removed freely without damage to the sealing area in the body.
13. Integral body seatface are stellite

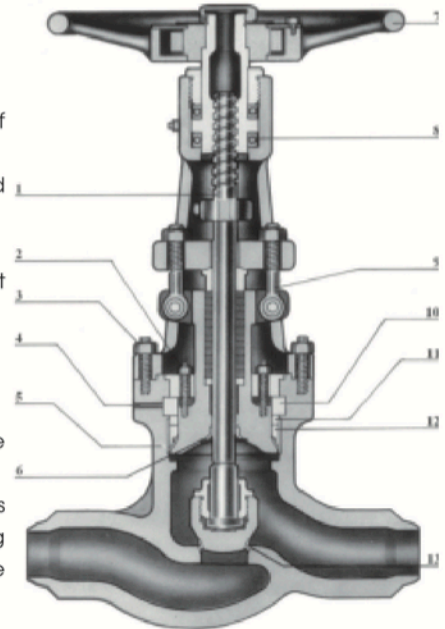

## Design Data Feature

1. Comply with requirement of applicable standard: ASME B 16.25, 16.34, MSS-SP-25, Optional API 600.
2. OS & Y construction, rising stem, non-rising hammer-blow handwheel.
3. Buttwelding end details of SUNE std. will be prepared in accordance with ASME B 16.25.

## Accessories

Accessories such as gear operators, actuators, bypasses, locking devices, and chainwheels are available to meet the customers requirements.

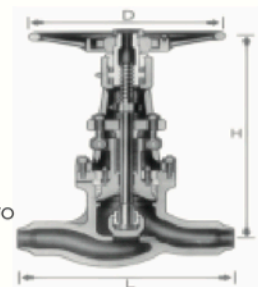

## Class 600

Dimensions in inches

Valve Size	2"	3"	4"	6"	8"	10"	12"	14"	16"	18"	20"	24"
50mm	80mm	100mm	150mm	200mm	250mm	250mm	350mm	400mm	450mm	500mm	600mm	
Face to Face (L)	7.00	10.00	12.00	18.00	23.00	28.00	32.00	35.00	39.00	43.00	47.00	55.00
Handwheel Diameter (D)	7.87	12.40	13.98	17.72	19.69	24.80	27.95	31.50	35.43	35.43	43.00	43.00
Height (H)	19.96	22.95	28.00	35.67	45.71	53.07	60.16	66.34	78.98	86.30	97.63	112.95

## Class 900

Dimensions in inches

Valve Size	2"	3"	4"	6"	8"	10"	12"	14"	16"	18"	20"	24"
50mm	80mm	100mm	150mm	200mm	250mm	250mm	350mm	400mm	450mm	500mm	600mm	
Face to Face (L)	8.50	12.00	14.00	20.00	26.00	31.00	36.00	39.00	43.00	48.00	52.00	61.00
Handwheel Diameter (D)	12.50	13.98	13.98	19.69	24.80	27.95	31.50	35.43	35.43	43.00	43.00	51.02
Height (H)	23.07	24.72	29.13	37.24	46.65	57.28	65.16	69.88	84.05	91.26	101.46	110.70

## Class 1500

Dimensions in inches

Valve Size	2"	3"	4"	6"	8"	10"	12"	14"	16"	18"	20"	24"
50mm	80mm	100mm	150mm	200mm	250mm	250mm	350mm	400mm	450mm	500mm	600mm	
Face to Face (L)	8.50	12.00	16.00	22.00	28.00	34.00	39.00	42.00	47.00	53.00	58.00	76.50
Handwheel Diameter (D)	15.50	13.98	15.75	24.80	27.95	27.95	31.50	35.43	43.00	43.00	51.02	57.50
Height (H)	23.07	28.03	33.70	41.77	44.82	55.00	59.76	64.57	82.24	88.46	103.30	117.60

## Class 2500

Dimensions in inches

Valve Size	2"	3"	4"	6"	8"	10"	12"
50mm	80mm	100mm	150mm	200mm	250mm	250mm	
Face to Face (L)	11.00	14.50	18.00	24.00	30.00	36.00	41.00
Handwheel Diameter (D)	15.50	15.50	15.75	24.80	27.95	27.95	31.50
Height (H)	25.63	31.14	37.44	46.41	49.80	61.11	66.40

## CHECK VALVES STANDARD FEATURES

### Service Recommendation

1. Swing Check valves shall operate in a manner which avoids:

a) The formation of an excessively high surge pressure as a result of the valve closing.

b) Rapid fluctuating movements of the valve closure member.

To avoid the formation of an excessively high surge pressure as a result of the valve closing, the valve must close fast enough to prevent the development of a significant reverse flow velocity which on sudden shut-off is the source of the surge pressure.

Thus, the closing speed of the valve should closely match the speed by which the forward flow retards.

Rapid fluctuating movements of the closure member must be avoided to prevent excessive wear of the moving valve parts which could result in early failure of the valve.

Such movements can be avoided by sizing the valve for a flow velocity which forces the closure member firmly against a stop.

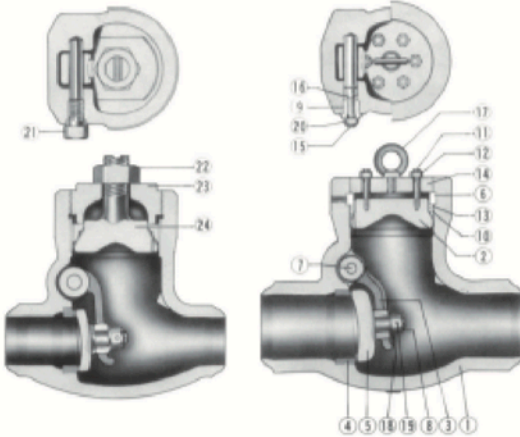

2. Swing check valves may also be mounted in the vertical position, provided the disc is prevented from reaching the stalling position. However, the closing moment of the disc due to its weight is very small in the fully open position, so the valve will tend to close late. To overcome slow response to retarding flow, the disc may be provided with a lever-mounted weight or spring loaded.

### Pressure Rating

Class 600

Class 900

Class 1500

Class 2500

### Standard Parts and Materials

No.	PART NAME	A216 WCB	A217 WC6	A217 WC9	A217 C5	A351 CF8M
1	Body	A216 WCB	A217 WC6	A217 WC9	A217 C5	A351 CF8M
2	Cover	A216 WCB	A217 WC6	A217 WC9	A217 C5	A351 CF8M
3	Arm	A216 WCB	A217 WC6	A217 WC9	A217 C5	A351 CF8M
4	Body Seat Ring	A105 + Stellite	A182 F11 + Stellite	A182 F22 + Stellite	A182 F5a + Stellite	A240 316 + Stellite
5	Disc	A216 WCB + Stellite	A217 WCB + Stellite	A217 WC9 + Stellite	A217 WC5 + Stellite	A351 CF8M + Stellite
6	Retainer	A479-410	A479-410	A479-410	A479-410	A479-316
7	Pin	A479-410	A479-410	A479-410	A479-410	A479-316
8	Disc Nut	A194Gr8	A194Gr8	A194Gr8	A194Gr8	A194Gr8M
9	Plug	A307D	A479-304	A479-304	A479-304	A479-316
10	Gasket	Soft Steel	Soft Steel	Soft Steel	Soft Steel	316 S S
11	Cover Clamp Bolt	A193-B7	A193-B16	A193-B16	A193-B16	A193-B8
12	Nut	A194-2H	A194Gr4	A194Gr4	A194Gr4	A194Gr8
13	Adapter Ring	A479-410	A479-410	A479-410	A479-410	A479-316
14	Cover Clamp	C/S1045	C/S1045	C/S1045	C/S1045	A351CF8
15	Sealing Bolt	A479-410	A479-410	A479-410	A479-410	A479-316
16	Gasket Ring	Soft Steel	Soft Steel	Soft Steel	Soft Steel	Soft Steel
17	Eye Bolt	A105	A105	A105	A105	A105
18	Washer	A479-410	A479-410	A479-410	A479-410	A479-316
19	Split Pin	A580-304	A580-304	A580-304	A580-304	A580-304
20	Sealing Nut	A194-2H	A194-2H	A194-2H	A194-2H	A194Gr8
21	Plug Bolt	A307B	A479-304	A479-304	A479-304	A479-316
22	Cover Nut	A194-2H	A194-2H	A194-2H	A194-2H	A479-304
23	Cover	A216-WCB	A217 WC6	A217 WC9	A217 C5	A351 CF8M
24	Bonnet	A216-WCB	A217 WC6	A217 WC9	A217 C5	A351 CF8M

## PRESSURE SEAL CHECK VALVES

1. Sealing mechanism through spindle is of same construction as the one of pressure seal bonnet.

2. By inserting knockout pin in drilled hole, segmental thrust ring can be easily driven out of retaining groove.

3. The gasket can be removed freely without damage to the seat ring area in the body.

The bonnet joint remains tight under all operating conditions as the sealing pressure is always many times greater than the pressure of the fluid in the line, thereby eliminating leakage. The higher the internal pressure, the greater the sealing pressure.

4. Seat rings are stellite faced and securely welded in place.

5. Inner row of studs establish the initial seal of the Pressure Seal Joint.

6. Segmental thrust ring absorbs all the thrust applied by internal pressure.

7. A hardened stainless steel protective ring prevents deformation of the top portion of the soft metallic gasket.

To ensure secure connection between arm and disc nut, split pin is used.

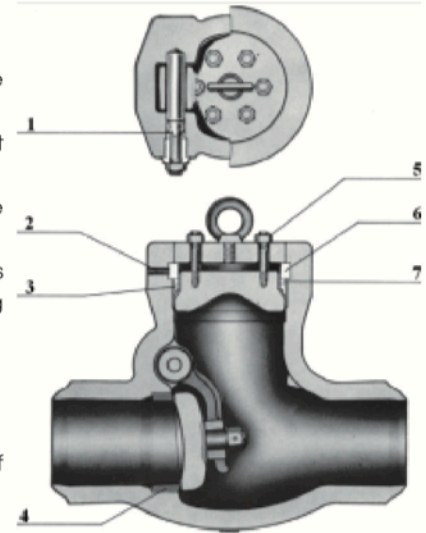

### Design Data Feature

1. Comply with requirement of applicable standard: ASME B 16.25, 16.34, MSS-SP-25, Optional API 600.

2. OS & Y construction, rising stem, non-rising hammerblow handwheel.

3. Buttwelding end details of SUNE std. will be prepared in accordance with ASME B 16.25.

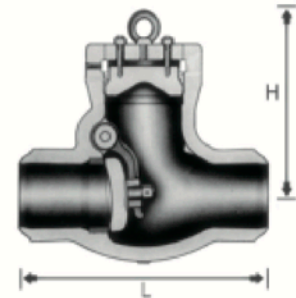

### Accessories

Accessories such as gear operators, actuators, bypasses, locking devices, and chainwheels are available to meet the customers requirements.

the customers requirements.

### Class 600

Dimensions in inches

Valve Size	2" 50mm	3" 80mm	4" 100mm	6" 150mm	8" 200mm	10" 250mm	12" 250mm	14" 350mm	16" 400mm	18" 450mm	20" 500mm	24" 600mm
Face to Face (L)	7.00	10.00	12.00	18.00	23.00	28.00	32.00	35.00	39.00	43.00	47.00	55.00
Height (H)	7.52	9.76	12.13	14.37	16.14	18.31	20.08	22.00	24.33	26.50	38.74	30.91

### Class 900

Dimensions in inches

Valve Size	2" 50mm	3" 80mm	4" 100mm	6" 150mm	8" 200mm	10" 250mm	12" 250mm	14" 350mm	16" 400mm	18" 450mm	20" 500mm	24" 600mm
Face to Face (L)	8.50	12.00	14.00	20.00	26.00	31.00	36.00	39.00	43.00	48.00	52.00	61.00
Height (H)	9.57	9.53	13.39	15.75	18.11	21.06	24.02	26.97	29.69	32.64	35.35	38.31

### Class 1500

Dimensions in inches

Valve Size	2" 50mm	3" 80mm	4" 100mm	6" 150mm	8" 200mm	10" 250mm	12" 250mm	14" 350mm	16" 400mm	18" 450mm	20" 500mm	24" 600mm
Face to Face (L)	8.50	12.00	16.00	22.00	28.00	34.00	39.00	42.00	47.00	53.00	58.00	76.50
Height (H)	9.57	11.81	13.78	15.91	19.29	22.64	26.85	29.61	31.57	34.53	36.89	40.63

### Class 2500

Dimensions in inches

Valve Size	2" 50mm	3" 80mm	4" 100mm	6" 150mm	8" 200mm	10" 250mm	12" 250mm
Face to Face (L)	11.00	14.50	18.00	24.00	30.00	36.00	41.00
Height (H)	10.24	13.78	15.94	17.72	20.55	23.62	26.93



## PRESSURE – TEMPERATURE RATINGS

COLD WORKING PRESURE, psig

ASME B16.34-2013

CLASS	TEMP °F	A216 WCB A105 & LF2	A352 LCC	A217 WC6 A182 F11	A217 WC9 A182 F22	A217 C5 A182 F5	A217 C12 A182 F9	A351 CF8 A182 F304	A351 CF8M A182 F316	A352 CN7M
600	-20 to 100	1480	1500	1500	1500	1500	1500	1440	1440	1200
	200	1360	1500	1500	1500	1500	1500	1200	1240	1035
	300	1310	1455	1445	1455	1455	1455	1075	1120	930
	400	1265	1405	1385	1410	1410	1410	995	1025	845
	500	1205	1330	1330	1330	1330	1330	930	955	780
	600	1135	1210	1210	1210	1210	1210	885	900	720
	650	1100	1175	1175	1175	1175	1175	865	885	
	700	1060	1110	1135	1135	1135	1135	845	870	
	750	1015	1015	1065	1065	1065	1065	825	855	
	800	825	825	1015	1015	1015	1015	810	845	
	850	640	640	975	975	975	975	790	835	
	900	460	445	900	900	745	900	780	830	
	950	275	275	640	755	550	755	765	775	
	1000	170	170	430	535	400	505	710	725	
	1050			290	350	290	345	650	720	
	1100			190	220	200	225	515	610	
	1150			130	135	125	150	410	475	
	1200			80	80	70	105	330	370	
1250							265	295		
1300							225	235		
1350							185	190		
1400							150	150		
1450							115	115		
1500							85	85		

CLASS	TEMP °F	A216 WCB A105 & LF2	A352 LCC	A217 WC6 A182 F11	A217 WC9 A182 F22	A217 C5 A182 F5	A217 C12 A182 F9	A351 CF8 A182 F304	A351 CF8M A182 F316	A352 CN7M
900	-20 to 100	2200	2250	2250	2250	2250	2250	2160	2160	1800
	200	2035	2250	2250	2250	2250	2250	1800	1860	1555
	300	1965	2185	2165	2185	2185	2185	1615	1680	1395
	400	1900	2110	2080	2115	2115	2115	1490	1540	1265
	500	1810	1995	1995	1995	1995	1995	1395	1435	1165
	600	1705	1815	1815	1815	1815	1815	1325	1355	1080
	650	1650	1765	1765	1765	1765	1765	1295	1325	
	700	1590	1665	1705	1705	1705	1705	1265	1305	
	750	1520	1520	1595	1595	1595	1595	1240	1280	
	800	1235	1235	1525	1525	1525	1525	1215	1265	
	850	955	955	1460	1460	1460	1460	1190	1255	
	900	690	670	1350	1350	1120	1350	1165	1245	
	950	410	410	955	1160	825	1130	1145	1160	
	1000	255	255	650	800	595	760	1065	1090	
	1050			430	525	430	515	975	1080	
	1100			290	330	300	340	770	915	
	1150			195	205	185	225	615	710	
	1200			125	125	105	155	495	555	
1250							400	440		
1300							340	350		
1350							280	290		
1400							225	225		
1450							175	175		
1500							125	125		



## PRESSURE –TEMPERATURE RATINGS

COLD WORKING PRESURE, psig

ASME B16.34-2013

CLASS	TEMP °F	A216 WCB A105 & LF2	A352 LCC	A217 WC6 A182 F11	A217 WC9 A182 F22	A217 C5 A182 F5	A217 C12 A182 F9	A351 CF8 A182 F304	A351 CF8M A182 F316	A352 CN7M
1500	-20 to 100	3705	3750	3750	3750	3750	3750	3600	3600	3000
	200	3395	3750	3750	3750	3750	3750	3000	3095	3590
	300	3270	3640	3610	3640	3640	3640	2690	2795	2330
	400	3170	3520	3465	3530	3530	3530	2485	2570	2110
	500	3015	3325	3325	3325	3325	3325	2330	2390	1945
	600	2840	3025	3025	3025	3025	3025	2210	2255	1800
	650	2745	2940	2940	2940	2940	2940	2160	2210	
	700	2665	2775	2840	2840	2840	2840	2110	2170	
	750	2535	2535	2660	2660	2660	2660	2065	2135	
	800	2055	2055	2540	2540	2540	2540	2030	2110	
	850	1595	1595	2435	2435	2435	2435	1980	2090	
	900	1150	1115	2245	2245	1870	2245	1945	2075	
	950	685	685	1595	1930	1370	1885	1910	1930	
	1000	430	430	1080	1335	995	1270	1770	1820	
	1050			720	875	720	855	1630	1800	
	1100			480	550	495	565	1285	1525	
	1150			325	345	310	375	1030	1185	
	1200			205	205	170	255	825	925	
1250							670	735		
1300							565	585		
1350							465	480		
1400							380	380		
1450							290	290		
1500							205	205		

CLASS	TEMP °F	A216 WCB A105 & LF2	A352 LCC	A217 WC6 A182 F11	A217 WC9 A182 F22	A217 C5 A182 F5	A217 C12 A182 F9	A351 CF8 A182 F304	A351 CF8M A182 F316	A352 CN7M
2500	-20 to 100	6170	6250	6250	6250	6250	6250	6000	6000	5000
	200	5655	6250	6250	6250	6250	6250	5000	5160	4320
	300	5450	6070	6015	6070	6070	6070	4480	4660	3880
	400	2280	5865	5775	5880	5880	5880	4140	4280	3520
	500	5025	5540	5540	5540	5540	5540	3880	3980	3240
	600	4730	5040	5040	5040	5040	5040	3680	3760	3000
	650	4575	4905	4905	4905	4905	4905	3600	3680	
	700	4425	4630	4730	4730	4730	4730	3520	3620	
	750	4230	4230	4430	4430	4430	4430	3440	3560	
	800	3430	3430	4230	4230	4230	4230	3380	3520	
	850	2655	2655	4060	4060	4060	4060	3300	3480	
	900	1915	1855	3745	3745	3115	3745	3240	3460	
	950	1145	1145	2655	3220	2285	3145	3180	3220	
	1000	715	715	1800	2230	1655	2115	2950	3030	
	1050			1200	1455	1200	1430	2715	3000	
	1100			800	915	830	945	2145	2545	
	1150			545	570	515	630	1715	1970	
	1200			345	345	285	430	1370	1545	
1250							1115	1230		
1300							945	970		
1350							770	800		
1400							630	630		
1450							485	485		
1500							345	345		



*Your Success is Our Commitment*

[www.mkucorp.com](http://www.mkucorp.com)

**Office :**

Jl. Maple Timur 3 Blok CC 08,  
Summarecon Bekasi, Jawa Barat

Jl. Palem Raja No 12 Taman Beverly  
Lippo Cikarang, Bekasi, Jawa Barat

**Email :**

[Info@mkucorp.com](mailto:Info@mkucorp.com)

**Phone :**

021 - 29450182